

Instructions

Flat Panel TV Cart

Model #: PLCAB5434E

Warranty begins the date that the item ships out of our warehouse. Metal carts have a limited lifetime warranty on all housing components; however, carts have a one year warranty on any electrical/mechanical components.

Note: This unit is easier to assemble with two people.

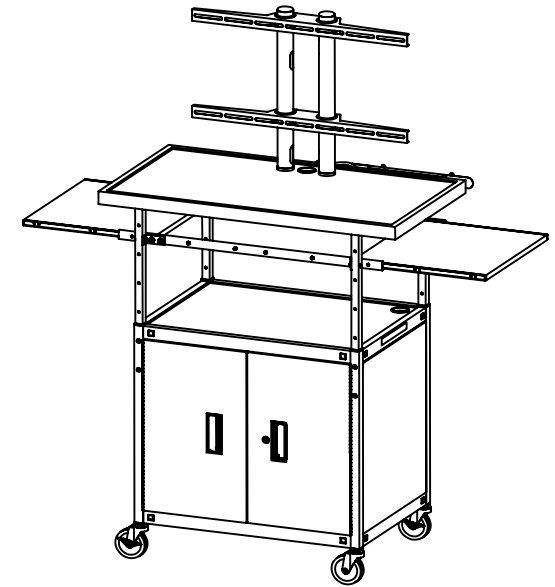











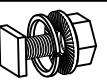

PLCAB5434E

Parts list

Qty.	Description	Qty.	Description	Qty.	Description
1	Top shelf with decal	2	Side panels	5 Set	Screws, washer and hex nuts (L)
1	Middle shelf	1	Rear panel	17 Set	Square head bolts, washer and serrated nuts (I)
1	Bottom shelf	1	Right door assembly	17 Set	Machine screws and serrated nuts (J)
4	Top legs	1	Left door assembly	13 Set	Screws and washer (K)
2	Bottom legs (Labeled "O")	2	Casters with brakes	3 Set	Screws and serrated nuts (E)
2	Bottom legs (Labeled "X")	2	Casters without brakes	2	Security screws for mounting the poles (F)
1	Cabinet shelf	1	Electrical bracket	2	Security screw (G)
4	Shelf support	1	Power cord	2	Hex head screw (H)
2	Horizontal mount	6	Screws (M)	2	Poles for supporting flat panel TV
1 Set	Pull out shelf				

Screw table

Some screws may have already screwed on the related parts.

A		M4x12	H		M10x20 On the bottom horizontal mount
B		M5x12	I		
C		M6x12	J		M6x40
D		M8x16	K		M5x12
E		M5x55	L		M5x12
F		M8x20 On the pole	M		M6x10
G		M10x20 On the top horizontal mount			



Pole



Horizontal mount

Tools required

Hex wrench
L key
Adjustable wrench/pliers
Rubber mallet

WARNING: Please keep the TV mounting screws A, B, C & D and the L keys in a secure location as they may be required for use with the flat panel TV at a later time.

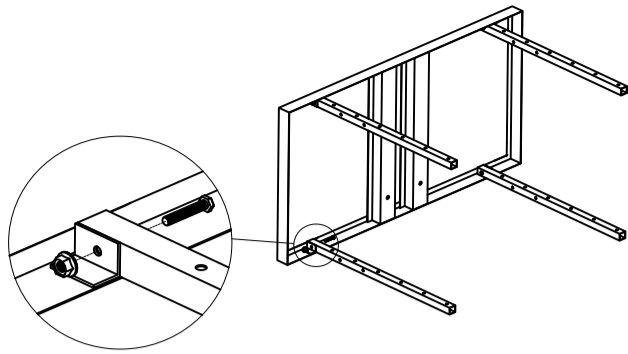

1. Insert top legs (legs with no wing bracket) onto top shelf (biggest shelf with decal). Make sure the holes are facing from front to back (shelf with decal is the front). Tighten top legs with screws and serrated nuts (see screw table J) as shown.

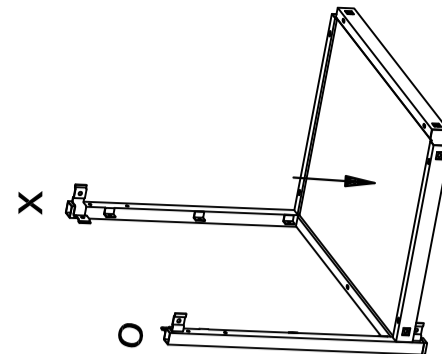

2. Lay two bottom legs marked "O" and "X" on floor with bracket facing inward. Make sure holes on the legs are facing up and down. Slide the width side of the bottom shelf (shelf without wire hole) onto the brackets.

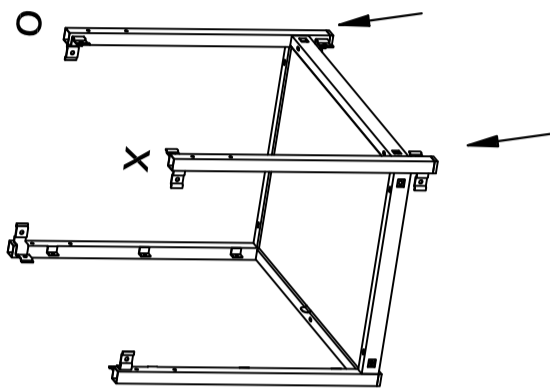

3. Slide the two remaining bottom legs onto the bottom shelf.

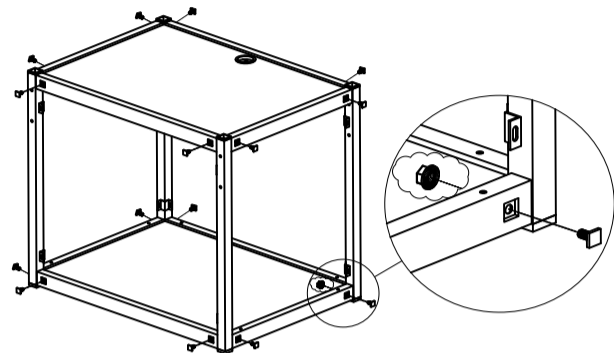

4. Slide the middle shelf onto the brackets and **HANG TIGHTEN** the shelves with screws (see screw table I) as shown. Make sure washer and nuts are together on the inside of the wing brackets. **Do Not Tighten Completely At This Time.**

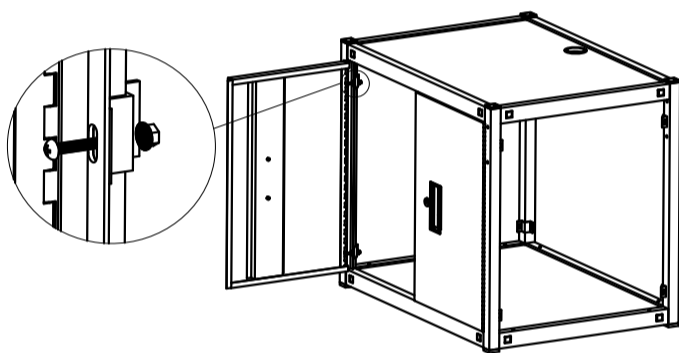

5. Install the two doors onto the frame with two machine screws (see screw table L) on each side as shown. **Do Not Tighten Completely At This Time.** Adjust the doors to make sure they close and lock OK.

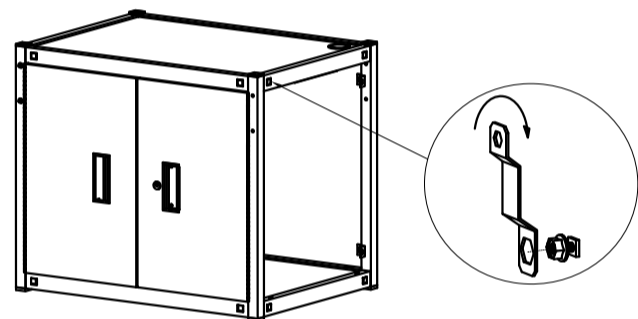

6. In order to have the unit properly aligned, close and lock the doors. Stand unit upright on a level surface. Gently rock unit left and right to realign and level the unit. **Tighten the four screws for the doors first.** Then **TIGHTEN ALL NUTS AND BOLTS WITH WRENCHES AT THIS TIME AS SHOWN.** Unit should now be properly aligned and level. If unit is not level at this time, repeat the above steps before proceeding to step 7.

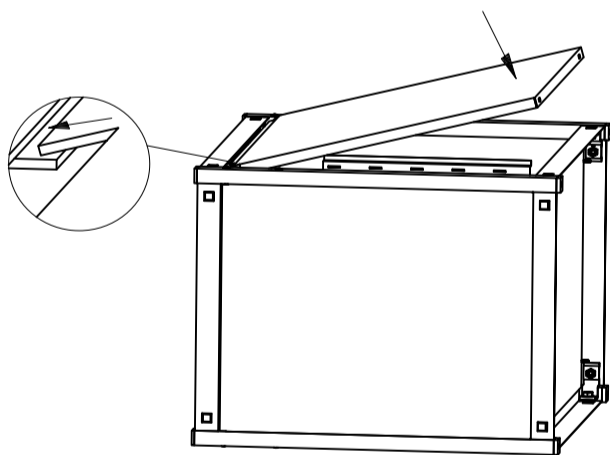

7. Slide the cabinet panels onto the sides and back as shown.

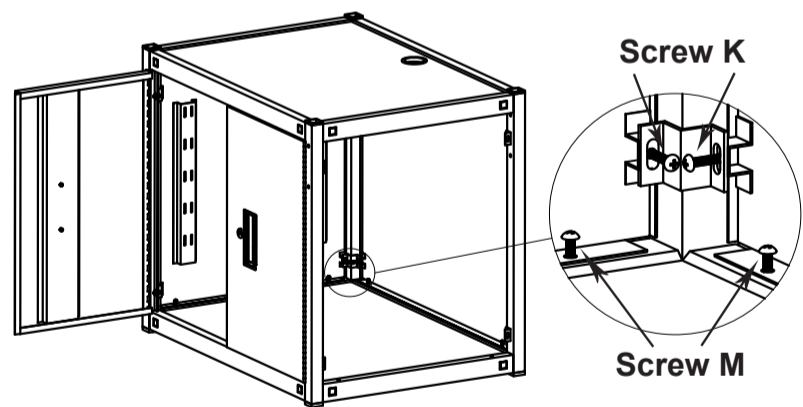

8. Fasten the cabinet panels (see screw table K & M) onto the cart as shown.

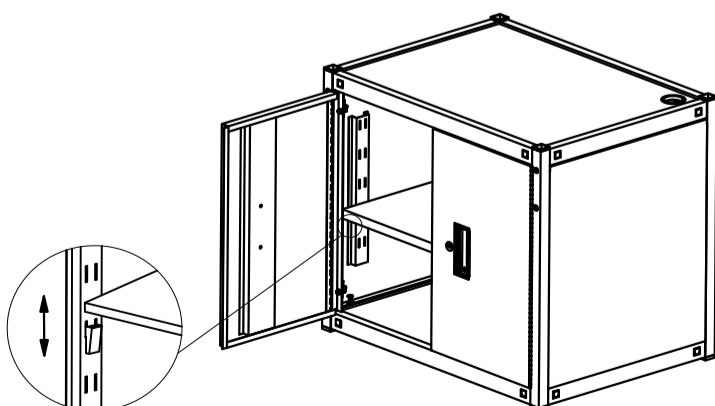

9. Insert shelf support to desired height. Put the cabinet shelf on top of the shelf support as shown.

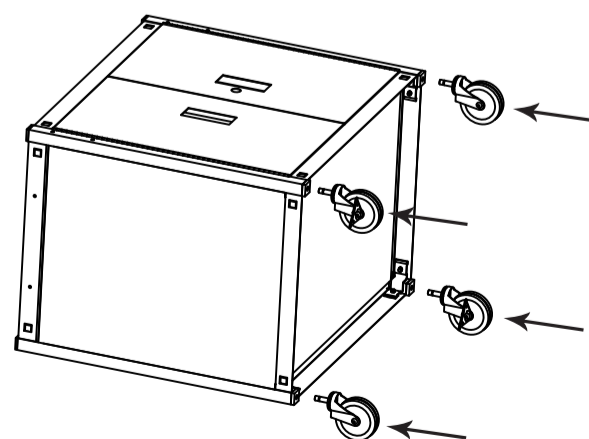

10. Insert casters with brakes into opposite corner holes on the bottom of the unit as shown. Insert the other casters into the remaining holes.

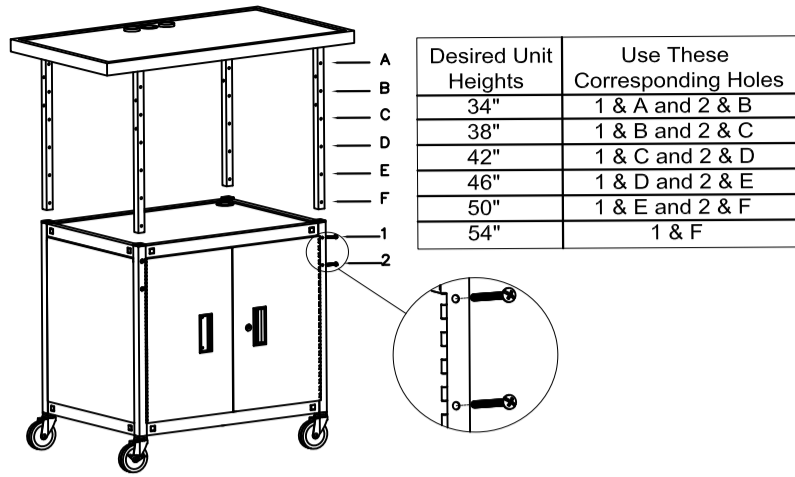

11. Put the top section assembly over the bottom section at desired height. Tighten the top section onto the bottom with two screws (see screw table J) on each leg as shown.

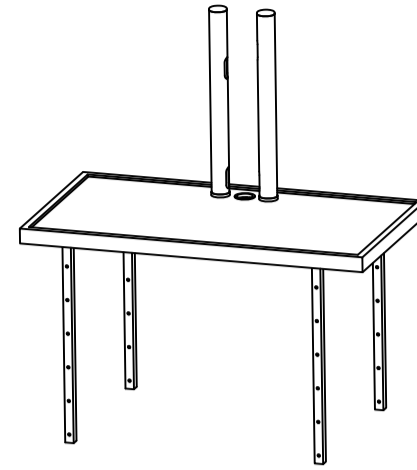

12. Insert the two supporting poles onto the holes on top shelf. Wire holes can face inside or outside.

13. Insert the two horizontal mounts onto the supporting poles. Note: The mount with adjustable screw (see screw table H) should go on the bottom. Screw (see screw table G) the top mount to desired height from A to F. Adjust the bottom mount height according to the TV screw position as shown.

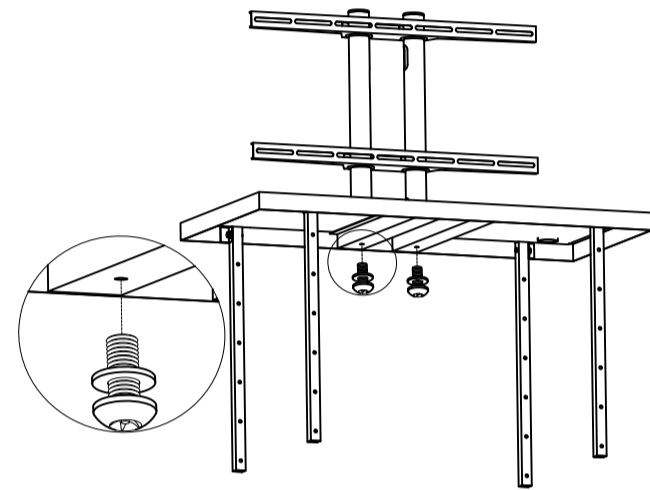
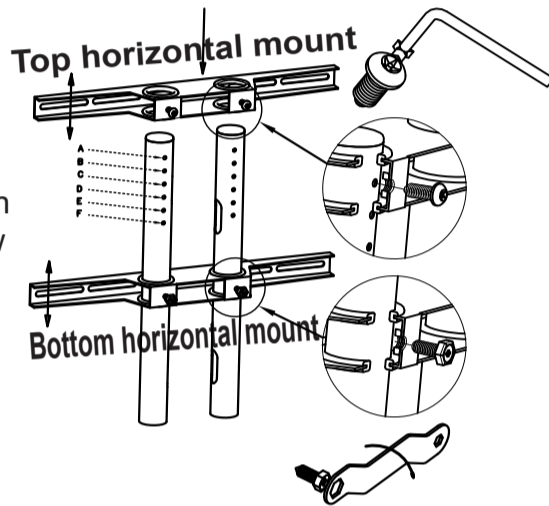

14. Tighten the two supporting poles onto the top shelf with two security screws as shown (see screw table F).

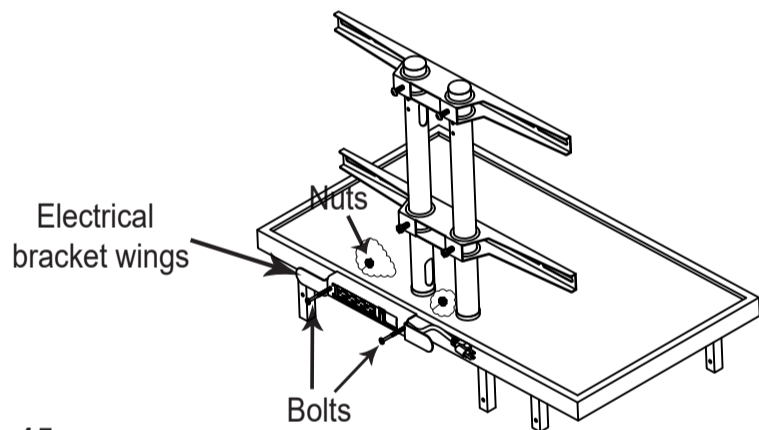

15. Electrical bracket assembly instruction
 A. Push power cord into cord winder bracket.
 B. Attach electrical bracket to back side of top shelf with two nuts and bolts (see screw table E). Tighten nuts and bolts securely. Wrap power cord around wings of the bracket.

16. Pull out shelf assembly

Adjust the length of the pull out shelf as shown on Fig. A by loosening the screws and tightening again so that the width of the pull out shelf matches the width of the cart. Tighten the pull out shelf to the cart with the screws (see screw table J) as shown on Fig. A and Fig. B.

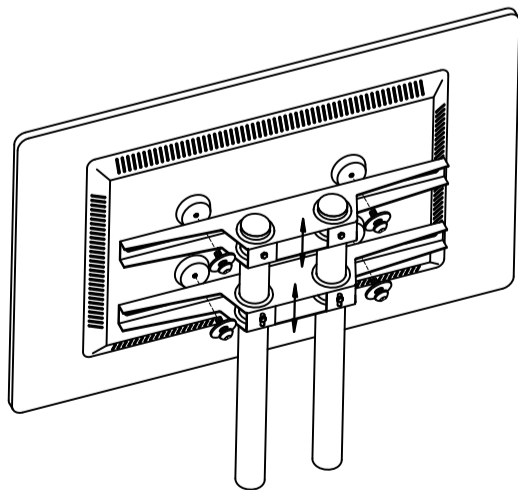
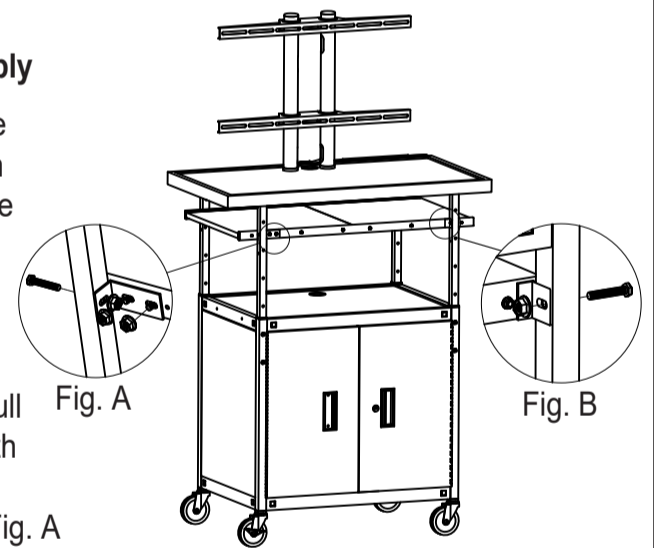

17. Use the appropriate security screws needed (M4, M5, M6 or M8, see screw table A, B, C or D) to fasten the flat panel TV onto the horizontal mounts as shown.

WARNING: Please keep the TV mounting screws A, B, C & D and the L keys in a secure location as they may be required for use with the flat panel TV at a later time.